



Supercal 5S (MC)

Static Heat- and Cooling Meter
DN 15 - DN 500

Your benefits

- Fluid oscillation principle:
High stability and repeatability for a long-term and accurate measurement, even with poor water quality
- No moving parts:
Not sensitive to dirt, air bubbles and liquids with changing viscosity
- No straight section necessary up to DN40 and only 3 DN necessary for DN 50 and up:
High flexibility in building planning
- Rugged and durable calculator:
Particularly rugged construction of the casing and the mechanical and electrical connections
- NFC Interface:
For a simplified and user-friendly calculator configuration on site

Application

- High-end device for building management
- All applications in district heating and cooling or building automation
- Optimally suited for glycol and other mixtures
- As a replacement for mechanical impeller heat meters

Features

- Exchangeable measuring head
- Common spare parts from q_p 1 up to 1500 m³/h
- Complete range of pipes q_p 1 - 1500 m³/h
- Dynamic flow range:
 - 1 : 100 at q_p 1 - 25 m³/h
 - 1 : 50 at q_p 40 - 400 m³/h
 - 1 : 25 at q_p 800 - 1500 m³/h
- Protection class of flow sensor IP68
- For horizontal, up- and downstream pipes, threaded and flange fittings
- Direct pick-up of voltage pulses without reflectors
- Self-cleaning effect due to the fluid oscillating characteristic
- Corrosion resistant materials without moving parts (no wear)
- Temperature sensor Pt 500 (2- or 4-wires)
- Exchangeable calculator electronics while wiring remains in place
- Large, illuminated dot-matrix display (128 x 64 pixel)
- Freely configurable tariff and data logger functions (up to 2'175 entries)
- Battery (12+1-year) or mains powered for increased flexibility
- Integrated backup battery for metrological part
- Standard EN 1434 class 2
- Conformity according to the Directive Measurement Canada

Options

- Up to 2 option cards can be retrofitted, either Ex-Factory or on site, or replaced at any time without affecting the approval of the calculator:
 - M-Bus according to EN 13757
 - BACnet MS/TP (RS485) / Modbus (RS485) – requires mains supply
 - 2 Analogue outputs, 0-20 mA, 4-20 mA, 0(2)-10 VDC – requires mains supply
 - Radio communication - Wireless M-Bus
 - Further modules will follow as:
 - Analogue inputs
 - 2 relay outputs (state / pulse)
 - LON
 - Radio communication – LoRaWAN®

Dimension Diagram

Figure 1

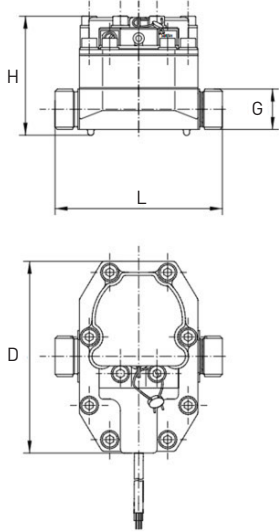

Figure 2

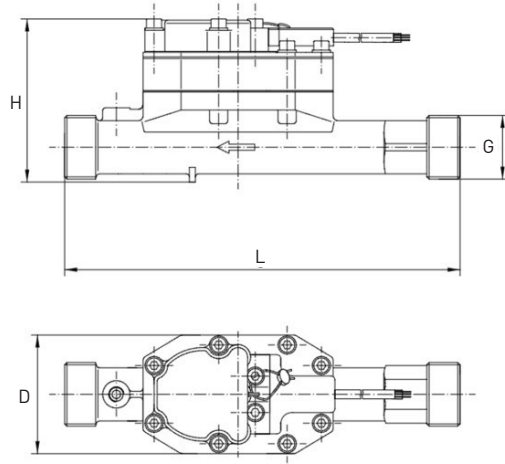
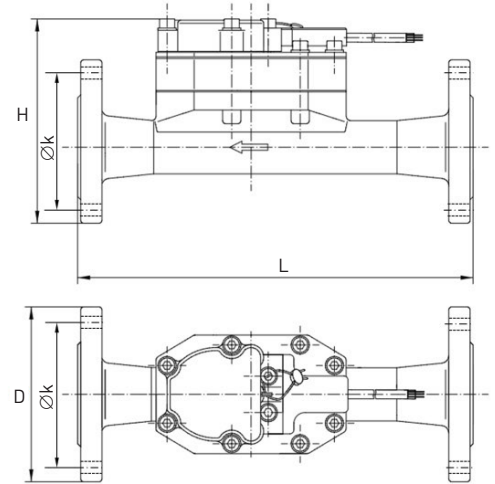
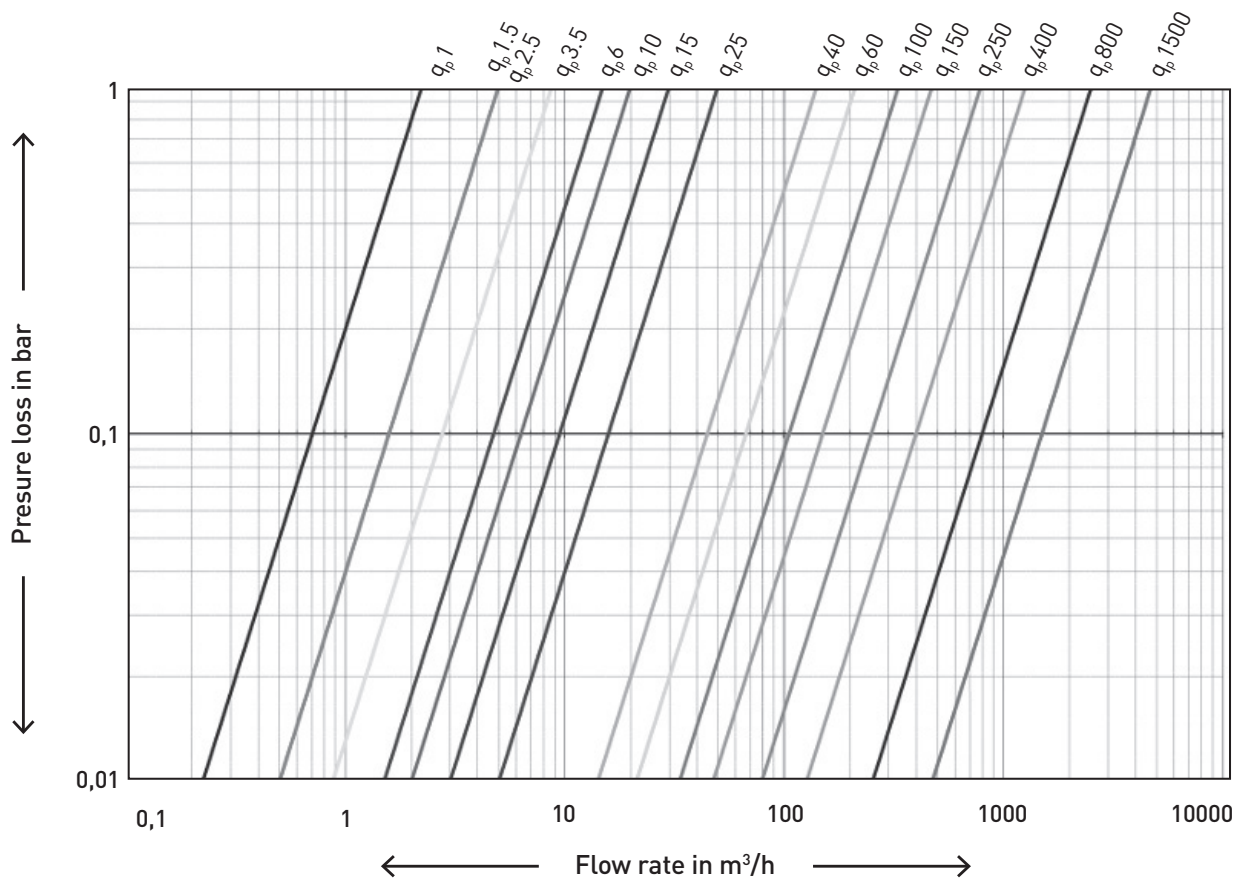

Figure 3



Typical Head Loss Curve



Calculator

Dimensions (HxWxD)	162 x 143 x 54 mm
Environment class C	E1/M1
Temperature sensor type	2- and 4-wire, Pt 500
Absolute temperature range	-20 °C to 200 °C
Approved temperature range	1 °C to 200 °C
Absolute temperature difference	1 K to 150 K
Homologation temperature difference	3 K to 150 K
Response limit	0.2 K
Temperature resolution t (display)	0.1 °C
Temperature resolution Δt (display)	0.001 K
Measurement accuracy	Better than requirements according to EN1434-1
Measuring cycle temperature measurement	
■ Battery operated (D-cell)	10 s to 30 s (depends on flow rate)
■ Mains operated	3 s to 30 s (depends on flow rate)
Ambient temperature in operation	5 °C to 55 °C
Transport and storage temperature	-20 °C to 70 °C (dry environment)
Ambient humidity	< 93% relative humidity
Display	Illuminated (if mains powered) dot-matrix display (128 x 64 pixel)
Display units	9 digits, MWh, m ³ , °C, K
Additional pulse inputs	Energy or volume
Protection class	IP65 in accordance to IEC 60529
Power supply options	Battery D-cell (12+1-year lifetime) OR Mains, 100-240 V AC, 50/60 Hz OR Mains, 12-42 V DC or 12-36 V AC
2 additional pulse inputs	Max. 200 Hz, 0-30 V DC
2 open collector pulse outputs	Max. 200 Hz, 0-30 V DC
Optical Interface	According to IEC 62056-21:2002
NFC Interface	According to ISO/IEC 14443 Type A
M-Bus Interface	According to EN 13757-2/3 Baudrate: 300 to 9'600 Bit/s 1 M-Bus standard unit load (1,5 mA)

Temperature sensor

Sensor element	Pt 500
Connection diagram	2- and 4-wire
Installation length	Depends on meter size

Flow sensor

Approved temperature range	5 to 130 °C
Environment temperature	5 to 55 °C
Storage temperature	-25 to 70 °C
Protection class	IP68

Installation

Pipeline:	horizontal —
	vertical
Meter head: (for horizontal installation)	+/- 45° 

The principle of fluid oscillator flow sensor

The main part of the flow passes through a Venturi nozzle in the pipe, creating the differential pressure to bypass the other part of the flow through the fluid oscillator.

In the oscillator the liquid is led to a nozzle and accelerated to a jet. Opposite of the nozzle the jet is redirected to the left or right into a channel that leads upwards to the sensor head equipped with a piezo sensor. The pressure of the liquid on the sensor creates an electrical pulse. The liquid flows back to the pipe through a return loop and redirects the jet into the other channel where the action is repeated and fluid oscillation is created. The frequency of this oscillation is linear proportional to the volume flow. A supplementary benefit is the self cleaning effect due to the oscillating character.

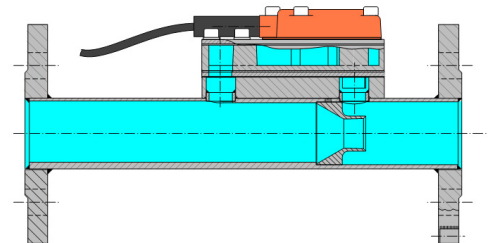

The animated top view on the oscillator shows the differences of velocity of the liquid. The jet accelerated by the nozzle with the highest velocity in red, slow velocity in blue.

