

## Superstatic 440

### Static Heat- and Cooling Meter



#### Application

The Superstatic 440 is a static heat- and cooling meter according to standard EN1434 class 2 based on the fluid oscillation principle, covering a wide range of flows for all applications in district heating and cooling or building automation. The fluid oscillation principle guarantees a high stability and repeatability for a reliable and precise measurement of flow and thermal energy.

#### Design

The heat- and cooling meter Superstatic 440 consists of the fluid oscillator flow sensor, the integrator Supercal 531, battery or mains powered, and a pair of temperature sensors. Consumption values can easily be read over the display or various data interfaces like optical probe, M-Bus, LON, BACnet, Modbus and so on.

#### Temperature sensor pair

The temperature sensors and the integrator Supercal 531 in combination with the Superstatic flow sensor are available as Pt 500 version. The temperature sensors are paired. They are always supplied in pairs and must not be separated, extended or shortened. In the case of temperature sensor pairs with a cable longer than 3 m, we recommend the exclusive use of screened temperature sensor pairs.

#### Measurement technique

The integrator Supercal 531 with mains power supply records every 3 seconds the supply and the return temperature, with battery power every 30 seconds (D-type battery). The recording of the flow is dependent of the pulse value of the flow sensor and is constantly updated. With the mean flow rate, the temperature difference and the heat coefficient the energy is calculated of the captured medium and displayed on the 8-digit LCD display.

### Fluid oscillator flow sensor: The principle

Picture 1: The main part of the flow passes through a Venturi nozzle in the pipe, creating the differential pressure to bypass the other part of the flow through the fluid oscillator.

In the oscillator the liquid is led to a nozzle and accelerated to a jet. Opposite of the nozzle the jet is redirected to the left or right into a channel that leads upwards to the sensor head equipped with a piezo sensor. The pressure of the liquid on the sensor creates an electrical pulse. The liquid flows back to the pipe through a return loop and redirects the jet into the other channel where the action is repeated and fluid oscillation is created. The frequency of this oscillation is linear proportional to the volume flow. A supplementary benefit is the self cleaning effect due to the oscillating character.

Picture 2: The animated top view on the oscillator shows the differences of velocity of the liquid. The jet accelerated by the nozzle with the highest velocity in red, slow velocity in blue.

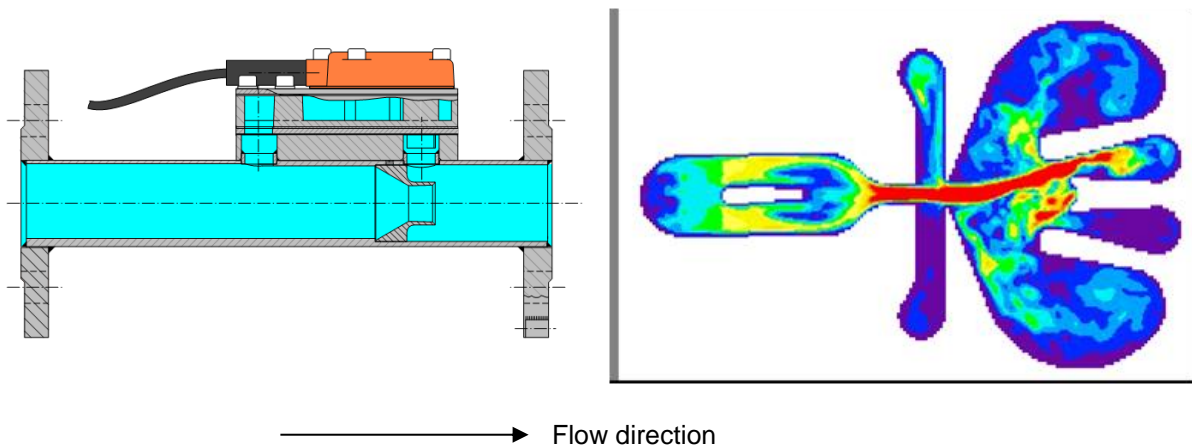

Picture 1: Section through the flow sensor

Picture 2: fluidic oscillation with jet (RED)

### Main features

The heat- and cooling meters Superstatic 440 are optimized for the measurement and calculation of energy consumption in district heating systems. They are also extremely well suited to use purely as volumetric flow meters for various media.

- Interchangeable measuring head
- Complete range of pipes 1 – 1500 m<sup>3</sup>/h
- Purchase and maintenance costs are reasonable compared with other static flow sensors
- Corrosion resistant materials
- Protection degree of flow sensor IP68
- Threaded and flange fittings
- No straight section necessary up to DN40
- No moving parts, therefore no wear
- Not sensitive to dirt
- Stable
- For horizontal, upstream and downstream pipes, independent mounting position
- Common spare parts 1qp 1 – 1500 m<sup>3</sup>/h
- Dynamic range:
  - 1 : 100 at qp 1 – 25 m<sup>3</sup>/h
  - 1 : 50 at qp 40 – 400 m<sup>3</sup>/h
  - 1 : 25 at qp 800 – 1500 m<sup>3</sup>/h
- Direct pick-up of voltage pulses without reflectors
- Measurement independent of medium
- Long-term, stable, accurate and reliable measurement, even with poor water quality

## Integrator

The Supercal 531 integrator is suitable for connecting Pt 500 temperature sensor pairs with 2- or 4-wire techniques. The factor of the pulse value is defined in the flow meter unit. The volume input value is defined when the unit is produced. The additional pulse inputs allow the connection of hot water, cold water, gas, oil and electricity meters. Consumption values can easily be read on the LCD display, via the optical interface, RS-232, M-Bus, LON, BACnet or Modbus.

## Power supply module

The flexible power supply concept of the Supercal 531 allows the following combinations

- 10 + 1 year battery, D type
- 220...240V alternating voltage 50/60 Hz
- 110...240V alternating voltage 50/60 Hz
- 12...24V alternating voltage 50/60 Hz
- 12...24V DC voltage

## Communication module

All versions can be ordered with two optional galvanically separated communication modules or the two communication modules can also be equipped later on when the integrator is in operation and this without compromising verification:

- Optical (default)
- RS 232
- Combined : 1 x RS-232, 3 x relay output, 4 x analogue output
- RS 232 with two additional relay outputs
- Relay module
- M-Bus module (factory assembly or post-assembly)
- M-Bus module two additional relay outputs
- Analogue module 2 outputs 4-20 mA
- Analogue module 2 inputs 0-20 mA or 4-20mA or 0-10V
- LON module
- BACnet module
- Modbus module

## Data storage

The Supercal 531 has in case of power failure two non-volatile EEPROMs for extensive data safety storage. In both EEPROMs the data are updated every hour. The first non-volatile memory is located inside on the printed circuit board of the relevant calibration and measurement part of the integrator and stores the following data:

- Parameters of the integrator and configuration parameter
- Cumulated energy
- Cumulated volume
- Customer specific tariff
- 15 monthly values
- 32 maximum values
- 32 average values
- Two set day
- Cumulated energy or volume on the set day
- Operating hours
- Date and time
- MET serial number (integrator upper part, calibration and measurement part)
- pulse value of the flow meter

The second non-volatile EEPROM is located on the printed circuit board in the integrator base part and stores the following parameters:

- MIO serial number (integrator base part, printed circuit board)
- identification number and customer number
- pulse value of additional meters 1 and 2
- cumulated values of additional meters 1 and 2
- unit of additional meters 1 and 2
- M-Bus address (primary and secondary)
- baud rate (M-Bus)
- pulse value of the pulse output
- parameter setting of the analogue outputs
- alarm and threshold value

This EEPROM ensures a smooth exchange of the calibration and measurement relevant part, without a new entering of the configuration of the communication.

### Supply and return temperature

The Temperatures are displayed with one decimal. Temperatures under 0°C are shown with a – (minus) sign. The display range is –20...200°C.

### Set day values

The Supercal 531 has two set days. On set day the cumulated energy, volume, tariff values and additional pulse inputs are stored with date.

### Solar- and cooling installations

The integrator units, calibrated for water ensure also with glycol mixtures a precise measurement, as the average mixing ratio can customized over the optical interface. The Supercal 531 processes and computes also negative temperatures. The dust proof and splash water-protected housings, IP65, is especially suitable for cooling installations. For these customized mixing ratios no official approvals are possible. The integrator Supercal 531 has programmed more than 70 different cooling medium and countless coolant-water mixtures can also be defined by software.

### Cooling energy

The cooling energy in combined heat/cooling applications is stored in another memory than the heat energy. The cooling energy has the same physical unit as the heat energy.

**TECHNICAL DATA SUPERSTATIC 440**

**Dimensions fluid oscillator flow sensor**

**Dimensions brass pipes (DN 15 – DN 40)**

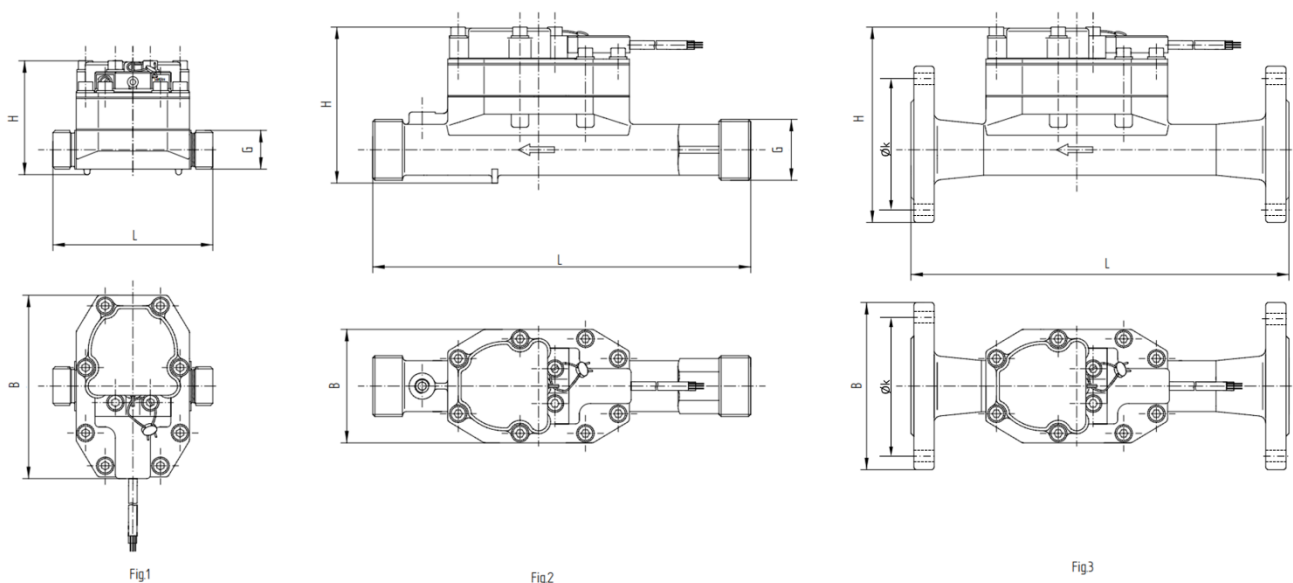

qp	DN	G	PN	Fig. No	B (mm)	H (mm)	L (mm)	Øk (mm)	# bolts (M)
1 m <sup>3</sup> /h	---	3/4"	16 / 25	1	125	79	110		-
1 m <sup>3</sup> /h	---	1"	16 / 25		125	79	190		-
1.5 m <sup>3</sup> /h	---	3/4"	16 / 25		125	79	110		-
1.5 m <sup>3</sup> /h	---	1"	16 / 25		125	79	190		-
2.5 m <sup>3</sup> /h	---	1"	16 / 25		125	79	190		-
3.5 m <sup>3</sup> /h	---	1 1/4"	16 / 25	2	78	105	260		-
3.5 m <sup>3</sup> /h	25	---	16 / 25	3	115	134	260	Ø 85	4 (M12)
6 m <sup>3</sup> /h	---	1 1/4"	16 / 25	2	78	105	260		-
6 m <sup>3</sup> /h	25	---	16 / 25	3	115	134	260	Ø 85	4 (M12)
10 m <sup>3</sup> /h	---	2"	16 / 25	2	78	122	300		-
10 m <sup>3</sup> /h	40	---	16 / 25	3	150	157	300	Ø 110	4 (M16)

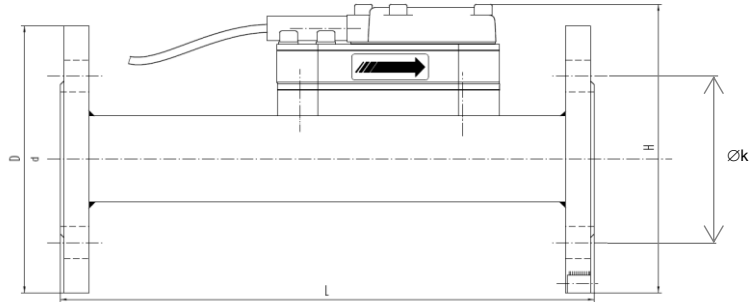
**Dimensions:****Stainless steel pipes (DN 50 – DN 250)****Spheroidal cast iron pipes (DN 50 – DN 150)****Steel pipes (DN 350 – 500)**

qp	DN	PN	L (mm)	D (mm)	H (mm)	Øk (mm)	# bolts (M)
15 m <sup>3</sup> /h	50	16, 25	270	165	171	Ø 125	4 (M 16)
25 m <sup>3</sup> /h	65	16, 25	300	185	189	Ø 145	8 (M 16)
40 m <sup>3</sup> /h	80	16, 25	225	200	203	Ø 160	8 (M 16)
40 m <sup>3</sup> /h	80	16, 25	300	200	203	Ø 160	8 (M 16)
60 m <sup>3</sup> /h	100	16	250	220	226	Ø 180	8 (M 16)
60 m <sup>3</sup> /h	100	25	250	235	235	Ø 190	8 (M 20)
60 m <sup>3</sup> /h	100	16	360	220	226	Ø 180	8 (M 16)
60 m <sup>3</sup> /h	100	25	360	235	235	Ø 190	8 (M 20)
100 m <sup>3</sup> /h	125	16	250	250	254	Ø 210	8 (M 16)
100 m <sup>3</sup> /h	125	25	250	270	270	Ø 220	8 (M 24)
150 m <sup>3</sup> /h	150	16	300	285	286	Ø 240	8 (M 20)
150 m <sup>3</sup> /h	150	25	300	300	300	Ø 250	8 (M 24)
150 m <sup>3</sup> /h	150	16	500	285	286	Ø 240	8 (M 20)
150 m <sup>3</sup> /h	150	25	500	300	300	Ø 250	8 (M 24)
250 m <sup>3</sup> /h	200	16	350	340	340	Ø 295	12 (M 20)
250 m <sup>3</sup> /h	200	25	350	360	360	Ø 310	12 (M 24)
400 m <sup>3</sup> /h	250	16	450	405	405	Ø 355	12 (M 24)
400 m <sup>3</sup> /h	250	25	450	425	425	Ø 370	12 (M 27)
800 m <sup>3</sup> /h	350	10	500	505	505	Ø 460	16 (M 20)
800 m <sup>3</sup> /h	350	16	500	520	520	Ø 470	16 (M 24)
1500 m <sup>3</sup> /h	500	10	500	670	670	Ø 620	20 (M 24)
1500 m <sup>3</sup> /h	500	16	500	715	715	Ø 650	20 (M 30)

**Flanges according to standard DIN-EN 1092-1 / DIN 2501 / ISO 7005-1**

**Technical Data Flow Sensor Superstatic 440**

qp	Threaded connection	Flanged connection	Length	Mat.	PN	Maximum flow qs	Minimum flow qi	Low flow threshold value (50°C)	Threaded hole for sensor	Weight.	Kvs value (at 20°C)	Pressure loss at qp
m <sup>3</sup> /h	G"	DN	mm		PN	m <sup>3</sup> /h	l/h	l/h		kg	m <sup>3</sup> /h	bar
1	(EN ISO 228-1) 3/4"	(ISO 7005-3) (15)	110	Brass	16/25	2	10	4	Yes	1.8	2.09	0.20
1	1"	(20)	190	Brass	16/25	2	10	4	Yes	2.3	2.09	0.20
1.5	3/4"	(15)	110	Brass	16/25	3	15	10	Yes	1.8	2.06	0.25
1.5	1"	(20)	190	Brass	16/25	3	15	10	Yes	2.3	5.44	0.09
2.5	1"	(20)	190	Brass	16/25	5	25	10	Yes	2.3	5.21	0.25
3.5	1 1/4"	(25)	260	Brass	16/25	7	35	15	Yes	1.96	7.46	0.16
3.5		25	260	Brass	16/25	7	35	15		1.96	7.46	0.16
6	1 1/4"	(25)	260	Brass	16/25	12	60	30	Yes	1.96	13.4	0.16
6		25	260	Brass	16/25	12	60	30		2.9	13.4	0.16
10	2"	(40)	300	Brass	16/25	20	100	50	Yes	6.1	20.9	0.25
10		40	300	Brass	16/25	20	100	50		7	20.9	0.25
		(ISO 7005-1)										
15		50	270	SS/CI	16/25	30	150	75		12.2	31.6	0.25
25		65	300	SS/CI	16/25	50	250	125		12.8	51.8	0.25
40		80	225	SS	16/25	80	800	400		11.5	142	0.09
40		80	300	SS/CI	16/25	80	800	400		12.2	142	0.09
60		100	250	SS	16/25	120	1200	600		14	210	0.10
60		100	360	SS/CI	16/25*	120	1200	600		14.6	210	0.10
100		125	250	SS/CI	16/25*	200	2000	1000		16	343	0.10
150		150	300	SS/CI	16/25*	300	3000	1500		26	514	0.10
150		150	500	SS	16/25	300	3000	1500		23	514	0.10
250		200	350	SS	16/25	500	5000	2500		30	857	0.10
400		250	450	SS	16/25	800	8000	4000		57	1372	0.10

SS: Stainless Steel; CI: Spheroidal cast iron \*: PN 25 only SS

						m <sup>3</sup> /h	m <sup>3</sup> /h	m <sup>3</sup> /h				
800		350	500	Steel	10/16	1600	32	16		90/105	2667	0.10
1500		500	500	Steel	10/16	3000	60	30		130/195	5000	0.10

**Degree of protection**

Standard IP68

**Ambient Temperatures**

Operation 5...55°C  
Storing and transport -25...70°C

**Measurement**

Approved temperature range 5...130°C

**Mounting**

Pipeline: horizontal   
vertical 

Meter head: sideways   
± 45°

### Pressure Loss

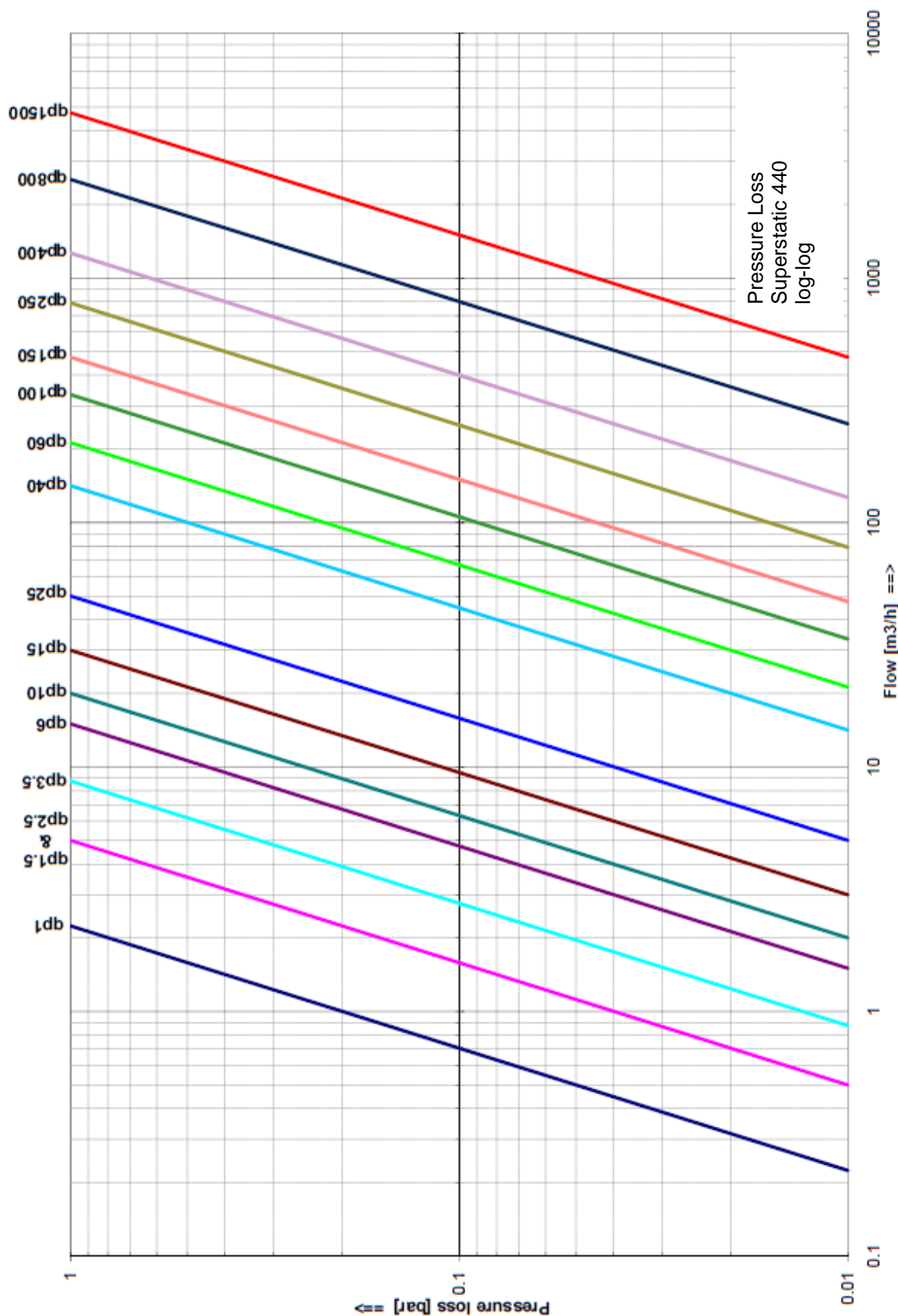



**Integrator Supercal 531**

**Temperature measurement**

Pt500	
2- and 4-wire	
Absolute temperature range	-20...200°C
Approved range	2...200°C
Absolute temperature difference	1...150K
Homologation range	3...150K
Response limit	0.2 K
Temperature resolution t (display)	0.1°C
Temperature resolution Δt (display)	0.01 K
Measuring	precision better than EN1434-1 request

**Measuring cycle Temperature measurement:**

30 seconds when battery operated (Type D)  
 3 seconds when mains operated

**Ambient Temperature**

Operation	5...55°C
Storing and transport	-25...70°C

**Display**

8 digits LCD-Display

**Display units**

Energy	MWh
Volume	m <sup>3</sup>
Additional pulse inputs	volume or energy
Temperature	°C

**Voltage supply modular optional**

Battery type D	10 + 1 year
Mains	110...240VAC or 220...240VAC – 50/60 Hz
Mains	12...24VAC 50/60 Hz or 12...24VDC

**Degree of protection**

Flow sensor	IP68
Integrator	IP65



**CE conformity according to**  
Directive MID 2014/32/EU  
RED 2014/53/EU

Detailed declarations of conformity can be found on our homepage: [www.gwf.ch](http://www.gwf.ch)

Modifications subject to change without notice

Data Sheet Superstatic 440 EN 16-03-2018

© GWF MessSysteme AG 2018